

**SQUARE 32 GAL. TRASH RECEPTACLE HOLDER  
MODELS # 12882 & 12940**

- Trash Receptacle has a 32 gallon capacity.
- Receptacle is built using 4 side panel window assemblies, a base with supporting cross members, 4 vertical supports and a cover with a protective hood over the large trash opening.
- Product will be shipped knocked down to reduce freight costs.
- Theft deterrent cable provided for attaching Cover to main body.
- Choose 1 of 2 window assemblies, either expanded or perforated steel.
- All assembly hardware to be included.
- Receptacle to be Powder Coated. Customer may choose 1 of 4 available colors. Custom colors available at additional expense.
- Anchor holes in base can be used to secure the trash receptacle in place. (Anchor bolts not included)
- Approximate weights:  
Cover for Unit = 25 lbs  
Expanded Steel Window Unit (Includes Cover) = 81 lbs  
Perforated Steel Window Unit (Includes Cover) = 94 lbs

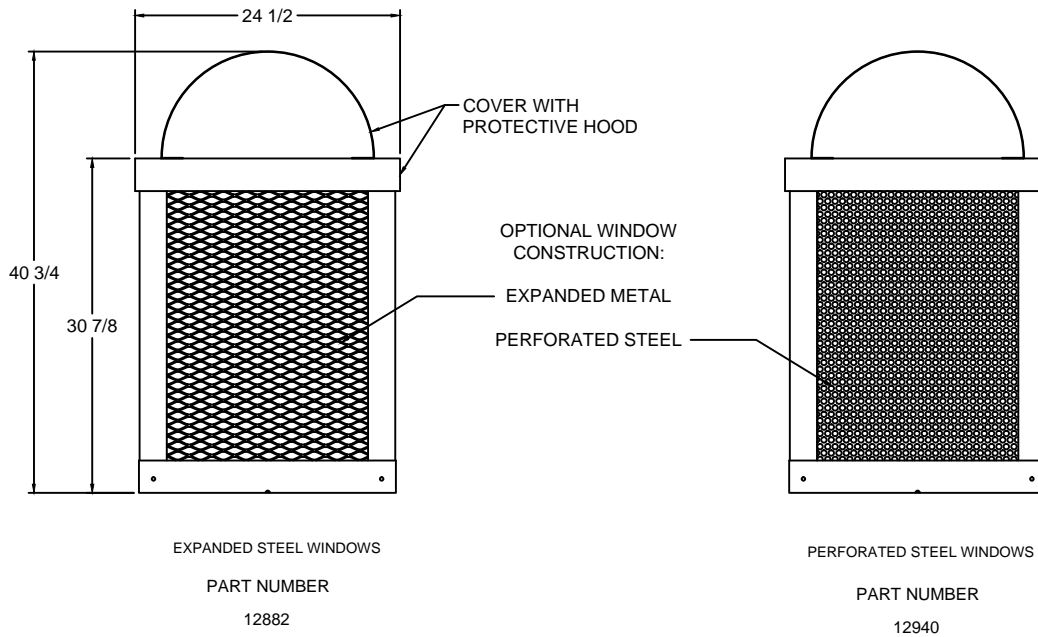
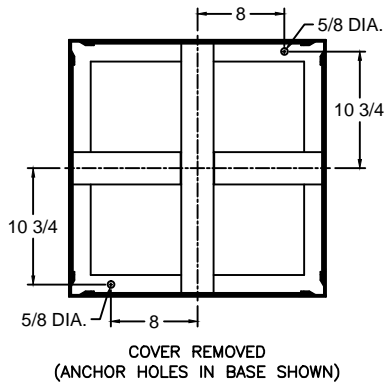

RECEPTACLE WILL ACCEPT A 21" DIA x 27" TALL WASTE RECEPTACLE

**WARNING: MUST BE PERMANENTLY MOUNTED**

CUSTOMER APPROVAL :

DATE :

**JAMESTOWN**  
**ADVANCED**  
**PRODUCTS**  
CORPORATION

THIS DRAWING, WHICH CONTAINS PROPRIETARY INFORMATION, IS THE PROPERTY OF JAMESTOWN ADVANCED PRODUCTS CORPORATION. IT SHALL NOT BE REPRODUCED IN ANY MANNER NOR DISCLOSED TO THIRD PARTIES WITHOUT WRITTEN PERMISSION OF JAMESTOWN ADVANCED PRODUCTS CORPORATION.

DATE : 08-13-07

PRODUCT PART NUMBER : 12882 & 12940

REV. NO. 2 12/11/15

PRODUCT DESCRIPTION :  
SQUARE 32 GAL. TRASH RECEPTACLE HOLDER

2855 GIRTS ROAD  
JAMESTOWN, NY 14701

PHONE 800-452-0639 -- FAX 716-483-5398 -- WWW.JAMESTOWNADVANCED.COM